

玻璃吸吊机/Glass lifter

一、功能说明/Function description

1、智能控制系统，超强声光报警装置。

Intelligent control system, super sound light alarm device.

2、无需任何电缆，内置 2 块超大蓄电池驱动，电量实时显示。

Without any cable, it is driven by two extra large batteries, with real-time power display.

3、省电、单块电池可使用 3-5 天，充电电压 220V。

Power saving, single battery can be used for 3-5 days, charging voltage is 220V.

4、美国进口 Thomas 直流无油真空泵，吸力超强，安全可靠。

Thomas direct current oil-free vacuum pump imported from the United States has super suction, safety and reliability.

5、可实现 0-90° 翻转搬运（特有省力装置，轻松易操作）。

It can realize 0-90 ° turning and handling (special labor-saving device, easy to operate).

6、可实现 0-360 度旋转搬运（特有省力装置，轻松易操作）。

It can realize 0-360 degree rotary handling (special labor-saving device, easy to operate).

7、真空压力不足时声光报警，并高效自动补气（只需 1.5 秒）。

When the vacuum pressure is insufficient, it will give an audible and visual alarm, and automatically replenish air efficiently (only 1.5 seconds).

8、机架采用组合式设计，吸盘位置可调，并可手动关闭。

The frame adopts combined design, the position of suction cup can be adjusted, and it can be closed manually.

9、吸盘调节无需任何工具、徒手变换机架样式。

The suction cup adjustment does not need any tools and hands to change the rack style.

10、高精度压力检测和高密封性真空储气桶，确保安全可靠。

High precision pressure detection and high sealing vacuum gas storage barrel ensure safety and reliability.

11、特有断电保护系统，断电后可持续保压 20 分钟以上。

The special power-off protection system can keep the pressure for more than 20 minutes after power-off.

12、真空压力数字显示，比传统指针式压力表精度高出 50% 以上。

The precision of vacuum pressure digital display is more than 50% higher than that of traditional pointer pressure gauge.

<h1>参数配置</h1> <p>Parameter configuration</p>			
载重/load KG	400KG	600KG	800KG
型号/Model	DP-X4P	DP-X6P	DP-X8P
自重/Dead weight KG	70KG	90KG	100KG
最小外形尺寸 Minimum dimension 长 L×宽 W×高 H (M)	0.85×0.75×0.3M	1.5×1.15×0.3M	1.5×1.15×0.3M
最大外形尺寸 Maximum dimension 长 L×宽 W×高 H (M)	1.2×0.9×0.3M	1.8×1.0×0.3M	2.5×1.0×0.3M
吸盘尺寸 Suction cup size mm	300mm (统一标准吸盘尺寸, 每款设备都可以通用) (unified standard suction cup size, each equipment can be used generally)		
单个吸盘承重/Single suction cup bearing KG	100KG (实际测试承重可达到 180KG 以上) 100kg (the actual test load can reach more than 180kg)		
旋转功能 Rotation function	360°手动旋转 (特有省力装置, 安全可靠, 易操作) 360 ° manual rotation (special labor-saving device, safe and reliable, easy to operate)		
翻转功能 reverse scan	90°手动翻转 (人性化设计, 可自动平衡, 快捷省力) 90 ° manual turning (humanized design, automatic balance, fast and labor-saving)		
电压/Voltage DC	DC12V (内置 2 块电池超长续航) (built in 2 extra long battery life)		
续航/Endurance	充一次电可用 3-5 天, 2 块电池交替使用 It can be used for 3-5 days for one charge, and two batteries can be used alternately		
加长杆 Extension bar MM	500MM (单边长度, 特殊玻璃规格可定制) 500mm (single side length, special glass specification can be customized)		
控制系统 Control system	有线遥控控制吸放 Wired remote control suction and discharge		
可定制 Customizable	注: 可根据贵司具体工艺需求、工件尺寸和重量定制。/Note: it can be customized according to your specific process requirements, workpiece size and weight.		
重量标准 Weight standard	常规玻璃重量=长×宽×厚×玻璃密度 2.5÷1000 000=玻璃重量 Conventional glass weight = length × width × thickness × glass density 2.5 ÷ 1000 000 = glass weight 例: 3660×2440×19×2.5÷1000 000=424KG		
安全系数 safety factor	根据欧洲 CE 有关起重设备安全规定, 及德国事故预防条例 UVV 18 and VBG 9a 中的安全规定, 真空吊具的最佳安全系数为 2.0, 例 FSRL280 吸盘单个吸力为 3139N, 除以安全系数 2.0 后, 载荷为 1570N/According to the European CE safety regulations on lifting equipment and the German accident prevention regulations uvv 18 and VBG 9a, the best safety factor of the vacuum sling is 2.0, for example, the single suction of fsrl280 suction cup is 3139n, divided by the safety factor of 2.0, the load is 1570n		

吸盘尺寸及组合/Suction cup size and combination

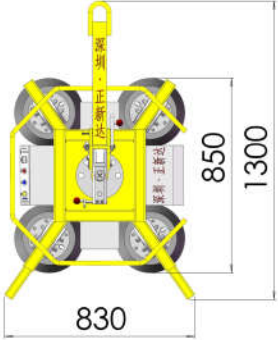
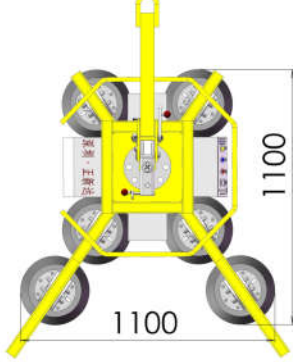
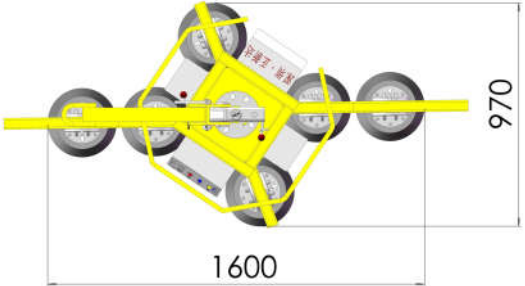
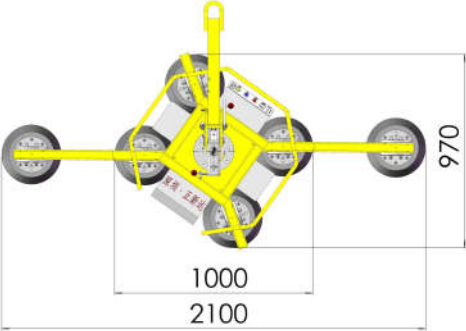
<p>DP-X4P</p> <p>4 个盘承重达 400KG</p> <p>4 discs bearing weight up to 400KG</p>	<p>DP-X6P</p> <p>6 个盘承重达 600KG</p> <p>6 discs bearing weight up to 600KG</p>
 <p>Diagram showing the DP-X4P suction cup assembly with dimensions: 830 (width) and 1300 (height). The assembly consists of a central yellow frame with four suction cups arranged in a square pattern.</p>	 <p>Diagram showing the DP-X6P suction cup assembly with dimensions: 1100 (width) and 1100 (height). The assembly consists of a central yellow frame with six suction cups arranged in a hexagonal pattern.</p>
<p>DP-X6P</p> <p>6 个盘承重达 600KG</p> <p>6 discs bearing weight up to 600KG</p>	<p>DP-X6P</p> <p>6 个盘承重达 600KG</p> <p>6 discs bearing weight up to 600KG</p>
 <p>Diagram showing the DP-X6P suction cup assembly with dimensions: 1600 (width) and 970 (height). The assembly consists of a central yellow frame with six suction cups arranged in a hexagonal pattern.</p>	 <p>Diagram showing the DP-X6P suction cup assembly with dimensions: 1000 (width) and 2100 (height). The assembly consists of a central yellow frame with six suction cups arranged in a hexagonal pattern.</p>
<p>DP-X8P</p> <p>8 个盘承重达 800KG</p> <p>8 discs bearing weight up to 800KG</p>	<p>DP-X8P</p> <p>8 个盘承重达 800KG</p> <p>8 discs bearing weight up to 800KG</p>

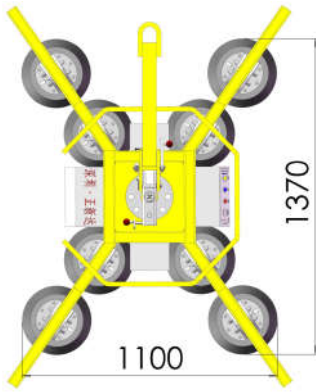

DP-X8P

8 个盘承重达 800KG

8 discs bearing weight up to 800KG

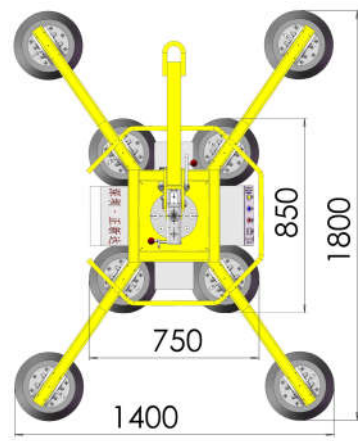

DP-X10P

10 个盘承重达 1000KG

10 discs bearing weight up to 1000KG

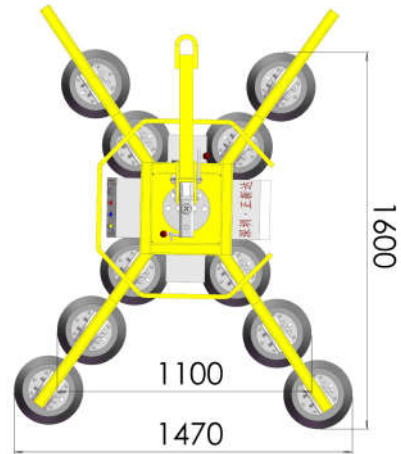

四、性能指标/performance index

项目内容 Project content	性能指标 performance index
额定负载 Rated load	<p>可对 400kg/600kg/800kg 钢化玻璃进行垂直竖立搬运 (在 60%真空度下测定)</p> <p>The toughened glass of 400kg / 600kg / 800kg can be handled vertically (measured under 60% vacuum)</p>
安全系数 safety factor	<p>4.0 倍, 通过体系认证 ISO9001:2008;符合欧洲 CE 安全规定</p> <p>4.0 times, passed the system certification ISO9001:2008, and met the European CE safety regulations</p>
安全警报 Security alert	<p>系统真空压力低于 60%, 蜂鸣器发出声光报警信号</p> <p>When the system vacuum pressure is lower than 60%, the buzzer will send out sound light alarm signal</p>
保压时间 Pressure holding time	<p>电池电量用完后系统真空压力由最高下降至 60%时所需的时间大于等于 10min</p> <p>The vacuum pressure of the system drops from the maximum to 60% when the battery is used up. Time required at 60% is greater than or equal to 10min</p>
吸放控制 Suction and discharge control	<p>遥控手柄控制</p> <p>Remote control handle control</p>
吊具自重 Self weight of spreader	<p>≈70kg/90kg/100kg</p>





五、主要部件明细/Details of main components

序号 Serial number	部件名称 Part name	型号 Model	供应商 supplier	单位 Compan y	数量 Numbe r
1	无油真空泵 Oil free vacuum pump	DC12V 最大真空度 90% DC12V maximum vacuum 90%	美国进口 Thomas Thomas imported from the United States	个 pcs	1
2	真空压力表 Vacuum pressure gauge	数字显示表 Digital display table	日本松下 Panasonic, Japan	个 pcs	1/2
3	吸盘 (进口硅胶) Suction cup (imported silica gel)	Φ300, 垂直吸力 /vertical suction 100kgf	德国 AEROLIFT Aerolift, Germany	套 sets	4/6/8
4	真空过滤器 Vacuum filter	G1/4"	德国 Germany	个 pcs	1
5	手动球阀 Manual ball valve	G1/4"	德国 Germany	个 pcs	4/6/8
6	真空吸盘缓冲支架 Vacuum suction cup buffer bracket	专用 Special-purpose	ZHENGXINDA	套 sets	4/6/8
7	主机架 Mainframe	50*50	ZHENGXINDA	套 sets	1
8	控制手柄 Control handle	10T 行车专用 Special for 10t driving	台湾禹鼎 Yuding, Taiwan	个 pcs	1
9	真空蓄能器 Vacuum accumulator	主梁集成 Girder integration	ZHENGXINDA	个 pcs	1
10	配电箱/Power Distribution Box	专用/Special-purpose	ZHENGXINDA	套 sets	4
11	电池/Battery	6-DZM-12	超威/Super Wei	个 pcs	2
12	充电器/Charger	2A	ZHENGXINDA	个 pcs	1

六、非人为或自然灾害等，整机保修壹年。

No man-made or natural disasters, the whole machine is guaranteed for one year.

七、相关案例/Relevant cases

<p>可旋转 360 度 Can rotate 360 degrees</p>	<p>超长玻璃 Extra long glass</p>
	
<p>500 米高空吊装 Hoisting at 500 m height</p>	<p>可翻转 90 度 Reversible 90 degrees</p>
	

弧形/Arc



平吊/Flat crane



下雪天使用/Use in snowy days



玻璃桥吊装/Glass bridge hoisting



石材吊装/Stone hoisting

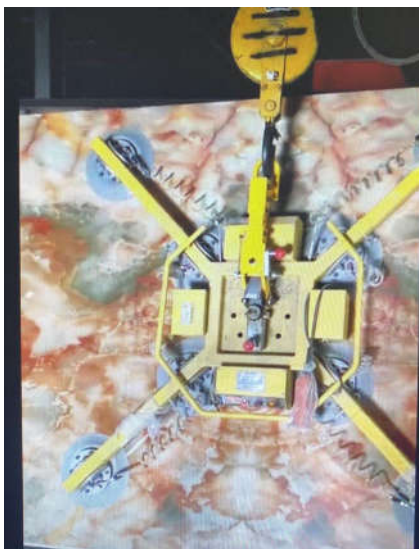

吊装板材/Lifting plate

